

FRENCH FITNESS

FF-ST200

FRENCH FITNESS ST200 SLAT BELT
COMMERCIAL TREADMILL

ASSEMBLY MANUAL



FEATURES

- Brand: French Fitness
- Bluetooth Module:
 - Enables wireless connectivity for compatible devices.
- USB Charging:
 - Keep your phone and accessories powered during workouts.
- Quick Buttons:
 - Instant speed/incline control for fast adjustments while training.
- Built-In Fan:
 - Helps keep users cool during intense sessions.
- Polar-Compatible Heart Rate Receiver (5KHz):
 - Supports accurate heart-rate monitoring with compatible chest straps.
- Electromagnetic Brake:
 - Provides smooth and controlled stopping performance for added safety.
- Bottle Holder:
 - Convenient storage for water bottles during workouts.
- 220V Power (110V Option Available):
 - Standard 220V supply, with 110V fully available for 40' container orders
- Wireless Chest Strap (Optional):
 - Optional accessory support for advanced heart-rate tracking.

TECH SPECS

- Product Type: Commercial Motorized Treadmill
- Motor: AC, 2.0 HP Continuous / 4.0 HP Peak
- Speed Range: 0.5 – 13.8 MPH (0.8 – 22 km/h)
- Console Max Speed: 13.8 MPH (22 km/h)
- Motorized Incline: 0 – 15% (16 Levels)
- Direction: Forward movement only (no reverse/backward operation).
- Belt Operation: Belt moves only when motor power is ON. When power is OFF, the belt remains stationary.
- Display: LED Dot-Matrix Display
- Workout Programs: 10 Total – 6 Preset, 1 HRC, 1 Manual, 2 Custom
- Features: Bluetooth Module, USB Charging, Quick Buttons, Fan, Polar-Compatible HR Receiver (5KHz), 220V
- Readouts: Time, Distance, Pulse, Calories, Speed, Incline
- Running Area: 22" × 58" Slat Belt (560 × 1470 mm)
- Set-Up Size: 74.0" L × 36.0" W × 65.0" H (188 × 91.4 × 165 cm)
- Maximum User Weight: 400 lbs (180 kg)
- Product Weight: 452 lbs (205 kg)

WARRANTY

- **Lifetime Frame Warranty**
- **10 Years Parts Warranty***
- **1 Year Labor Warranty***

*What is covered? See complete [French Fitness Warranty](#) details.

TABLE OF CONTENTS

OVERVIEW DRAWING	4
SAFETY INSTRUCTION	5
POWER REQUIREMENT	8
LEVEL ADJUSTMENT	9
MACHINE MOVEMENT	10
ASSEMBLY INSTRUCTIONS.....	11
ASSEMBLY STEPS	13
CONSOLE OPERATION INSTRUCTION.....	19
SPEED AND ELEVATION CHANGES	25

OVERVIEW DRAWING

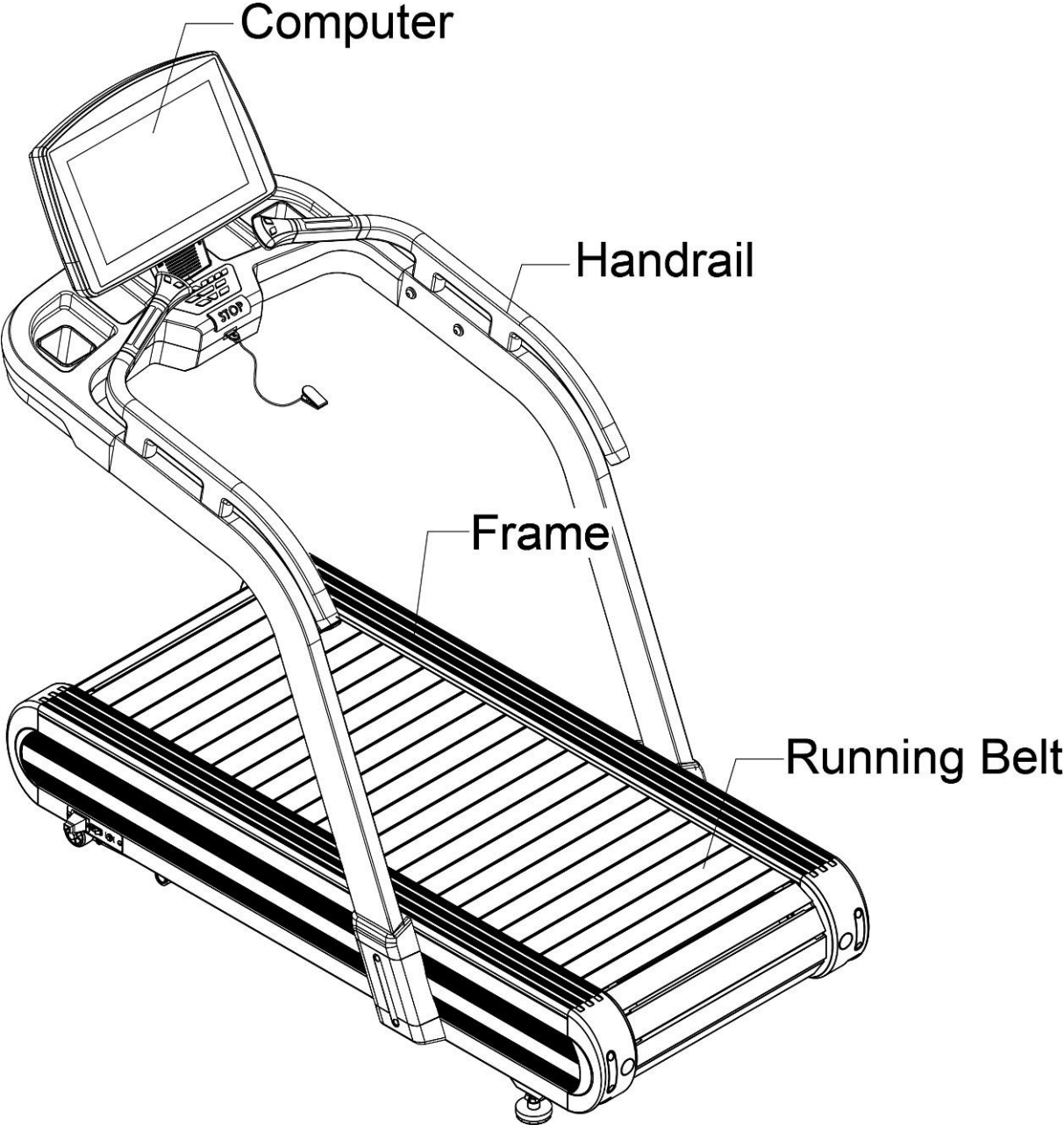

SAFETY INSTRUCTION

When using this product, basic precautions should always be followed, including the following:

Please read the instruction carefully before starting to use this product.

■ **DANGER – To reduce the risk of electric shock:**

- 1 Always unplug this product from the electrical outlet immediately after using and before cleaning.

■ **WARNING – To reduce the risk of burns, fire, electric shock, or physical injury:**

- 1 The product should never be left unattended while plugged in. Unplug the product from the outlet when not in use.
- 2 Close supervision is necessary when this product is used by or near children, invalids, or disabled persons.
- 3 Be sure to use the product only for its intended use as described in this manual. Do not use any attachment not recommended by the manufacturer in order to avoid any danger or accidents.
- 4 Never operate the product if it has a damaged cord or plug, if it is not working properly, if it has been damaged, or dropped into water. Please return the product to the service center of seller for examination and repair.
- 5 Do not carry this product by the supply cord or use the cord as a handle.
- 6 Keep the cord away from hot surfaces or ground.
- 7 Never operate the product with the air vents blocked. Keep the air vents free of lint, hair, etc.
- 8 Never drop or insert any objects into any openings.
- 9 Do not use or operate outdoors.
- 10 Do not operate where aerosol (spray) products are being used or where oxygen is thin.
- 11 Before turning the product power off, turn all controls to the off position then remove the

plug from the outlet.

- 12 Connect the product to a properly grounded outlet only.
- 13 If the power cord is damaged, be sure to ask the manufacturer for replacement to avoid accidents. The seller and correlative qualified professionals are as well as eligible.
- 14 This appliance is not intended for use by persons (including children) with reduced physical, sensory or mental capabilities, or lack of experience and knowledge, unless they have been given supervision or instruction concerning use of the appliance by a person responsible for their safety. Children should be supervised to ensure that they do not play with the appliance.
- 15 Incorrect or excessive training may cause injuries t health may results.
- 16 The equipment shall be installed on stable base and properly leveled.
- 17 A shall be safety area of 2,000mm x 1,000mm behind the equipment.
- 18 Maximum user weight is 150 Kgs.
- 19 When this treadmill is being used, it can not be folded at the same time.
Required to confirm the device completely stopped before folding
- 20 The safety level of the equipment can be maintained only if it is examined regularly for damage and wear.
- 21 Any of the adjustment devices that could interfere with the user's movement should not be left projecting.
- 22 Users correct ergonomic position on the equipment shown in Figure



23 When you are ready for running, please do not stand on the running belt. Before starting the machine, turn on the power. Put your hands on the side handrail and stand on the protection bar at both sides. And then press "START", when the motor is working in low speed, move your feet to the running belt to start running.

Please do not start the machine with high speed and do not jump to the machine, when there is an emergency, please hold the front handrail or side handrail and jump your feet from running belt to the side protection bar.

If there is any emergency, there are two emergent stop systems for you to stop the machine.

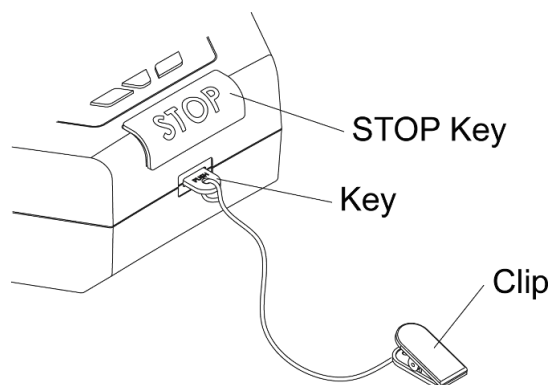

(a) Key and clip:

When you are running, please clip the clip to your cloth on the waist. If there is any danger, pull out the key with the cable to stop the machine.

(b) STOP key:

Press downwards the STOP key to make the key withdraw from the control box and the running belt will stop.

※ **Notice: Pull back the key to the control box to make the machine back to the standby status.**

24 Before using this product, you should step on it then turn on the product. Do not turn on the treadmill before step on it.

25 Running surface Width dimensions 560*1475mm

26 Customer Address

POWER REQUIREMENT

1.1. Power Requirement

■ This treadmill needs special power supply:

Power Voltage (V)	Frequency (HZ)	Rated Current (A)
100	50/60	15
120	50/60	15
200	50/60	8
220	50/60	8
230	50/60	8
240+	50/60	8

Wirings should be transported according to the electric law of the local country. High pressure wires, low pressure wires and underground wires should be transported separately and can't connect with or twist other wires.

Improper connection of the grounding plug can result in the risk of electric shock. Check with a qualified electrician or serviceman if you are in doubt as to whether the products are properly grounded. Do not modify the plug provided with the product – If it will not fit the outlet, have a proper outlet installed by a qualified electrician.

Figure
Grounding methods



LEVEL ADJUSTMENT

1.2. Level Adjustment

The treadmill will wobble during workout and the incline angles will be affected if it is placed on uneven ground.

The level adjustment method is as follows:

- 1 Turn A counter-clockwise to loosen it
- 2 Adjust B to the proper height
- 3 Turn A clockwise to tighten it.
- 4 The left side adjustment method is the same with the right side

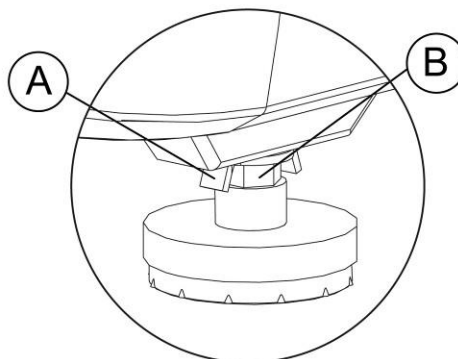
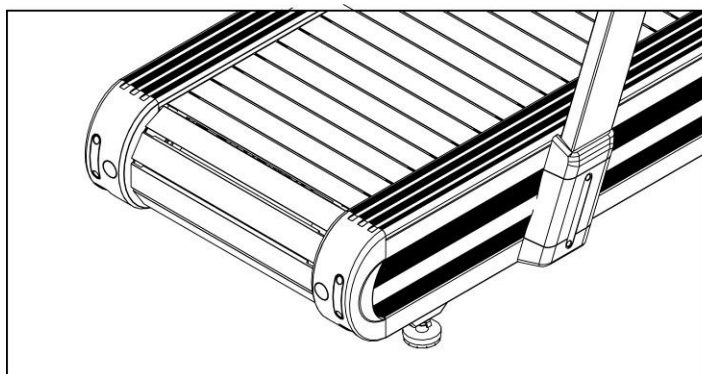

1.3. Power Switch

The Power Switch is on the bottom panel of the treadmill. 1 means on, 0 means off.

MACHINE MOVEMENT

1.4. Machine movement

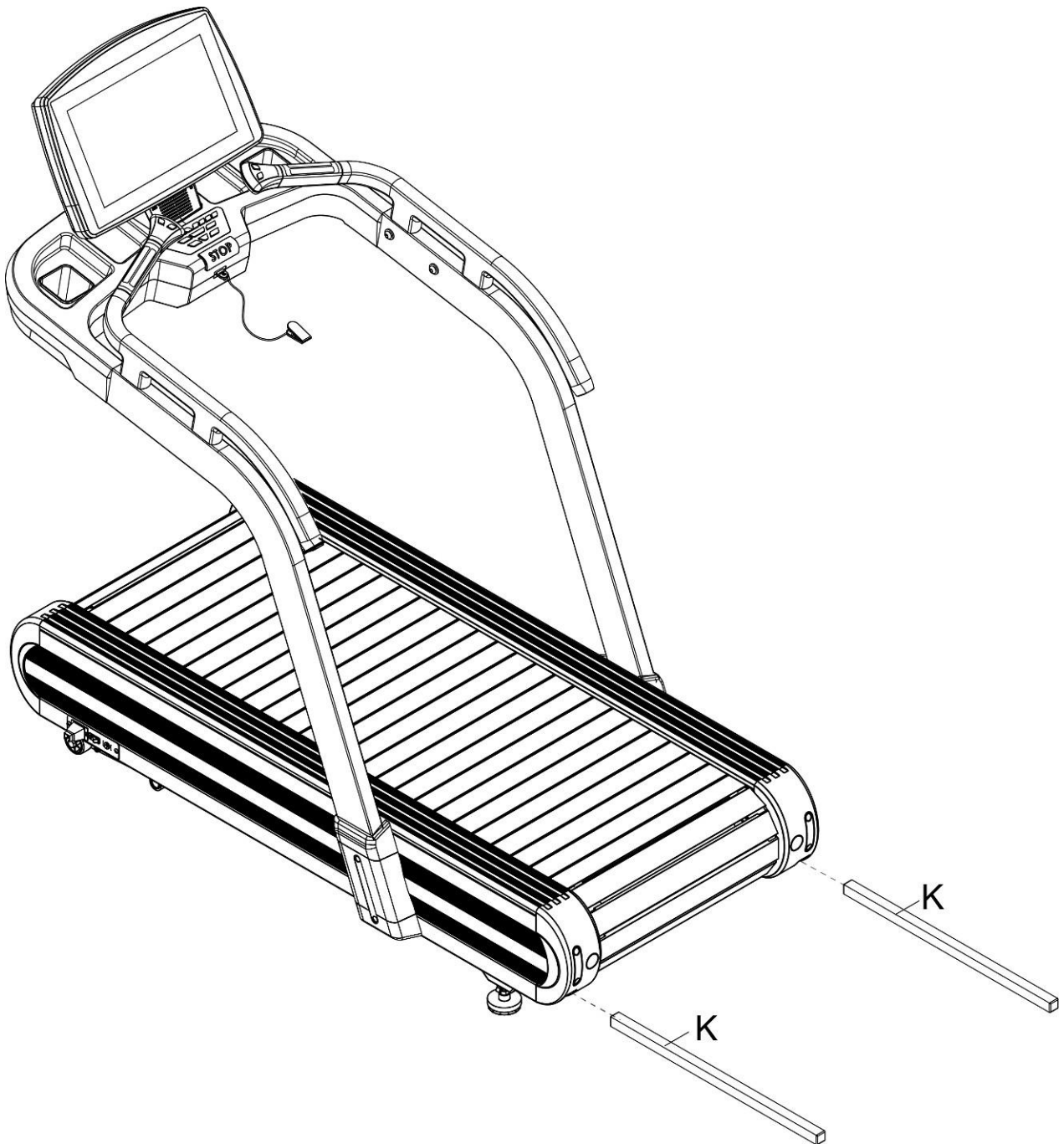

When the machine is moving, you can put the handling tube (K) into the back of the box to move the machine.

ASSEMBLY INSTRUCTIONS

Ready the operation instructions carefully before use, then choose a flat position to assemble.



This treadmill also can use other way to account the HRC. When in fitness, user can wear the chest pulse belt and the HRC will show in Pulse windows.

1.5. Pre-Assembly Check List

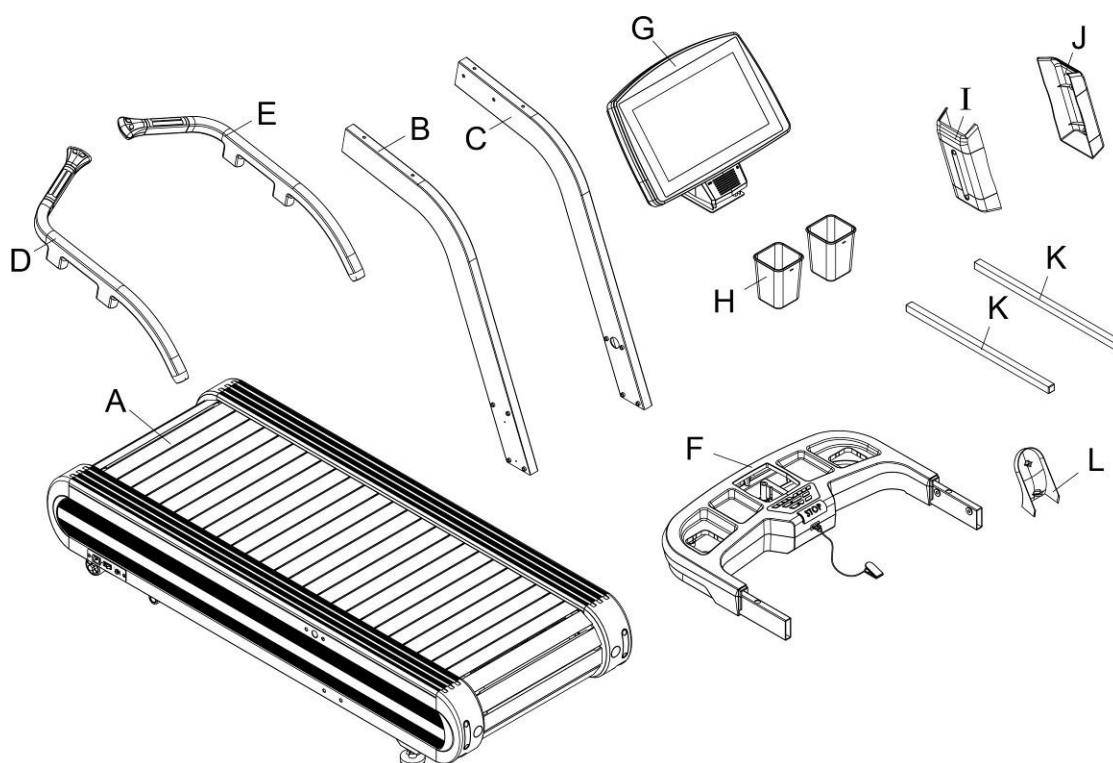

ITEM	Description	Qty	ITEM	Description	Qty
A	Treadmill frame	1	G	Electronic meter	1
B	Treadmill's hand-stand pipe (left)	1	H	Water cup	2
C	Treadmill's hand-stand pipe (right)	1	I	Stand pipe decorative cover (left)	1
D	Handrail pipe (left)	1	J	Stand pipe decorative cover (right)	1
E	Handrail pipe (right)	1	K	Transporting pipe	2
F	Water cup frame	1	L	Electronic meter decorative cover	1

1.6. Hardware Pack

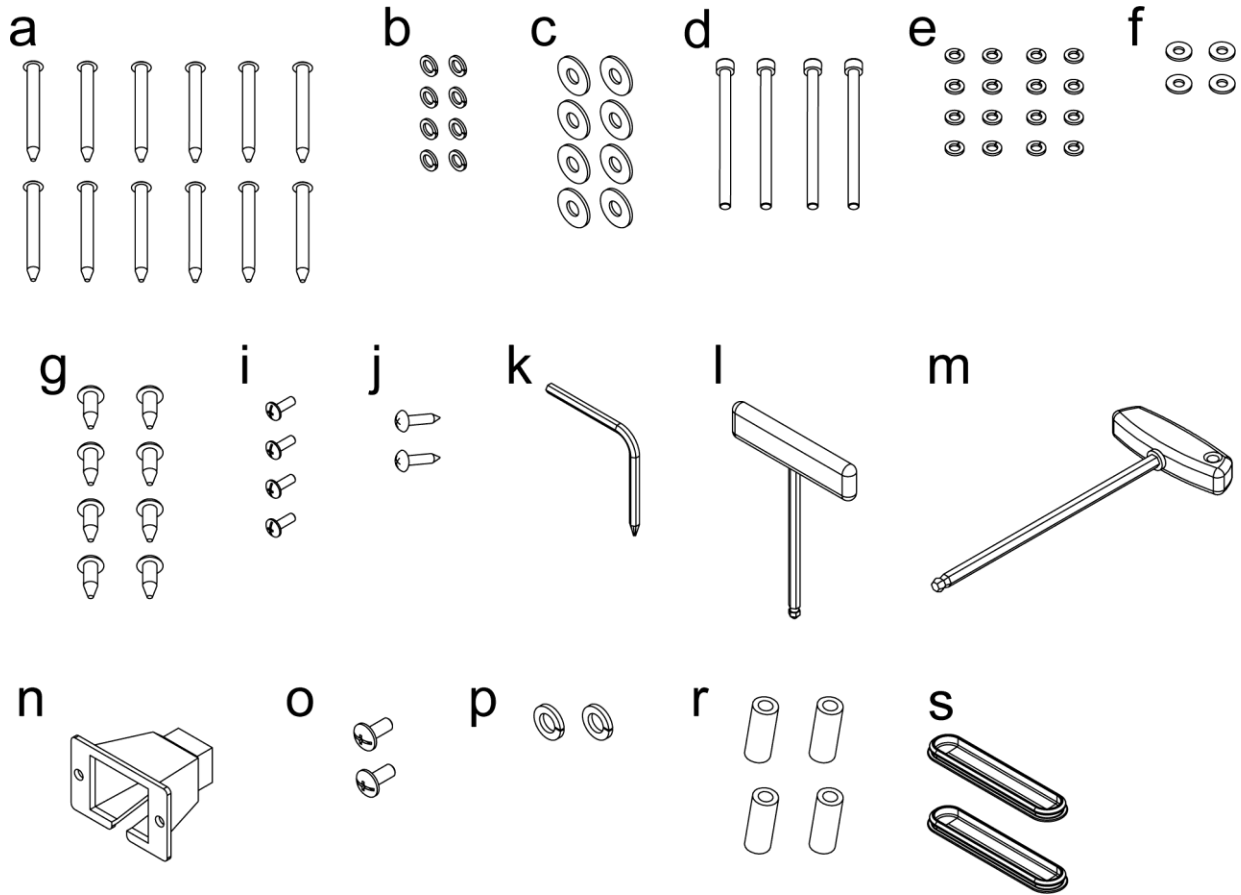

ITEM	Description	Qty	ITEM	Description	Qty
a	Inner hexagon steel screw M8x75 of umbrella head	12	k	Type L hexagon wrench + crossed screwdriver 5x35x115mm	1
b	Spring washer M10	8	l	Type T wrench 6mm	1
c	Washer $\phi 10 \times \phi 25 \times 2.0t$	8	m	Type T wrench 8mm	1
d	Inner hexagon steel screw M8x100 of socket head	4	n	Power cord switch sleeve	1
e	Spring washer M8	16	o	Umbrella head crossed screw M4x10	2
f	Washer $\Phi 8 \times \Phi 19 \times 2.0t$	4	p	Spring washer M4	2
g	Inner hexagon screw M10x20 of umbrella head, stainless steel	8	r	Bushing	4
i	Umbrella head crossed screw (tail cutting) M5x15	4	s	Oval rubber cap	2
j	Umbrella head crossed screw (tail cutting) M4x15	2			

ASSEMBLY STEPS

1.7. Assembly steps



Please remove this protective plastic sheet before installation.

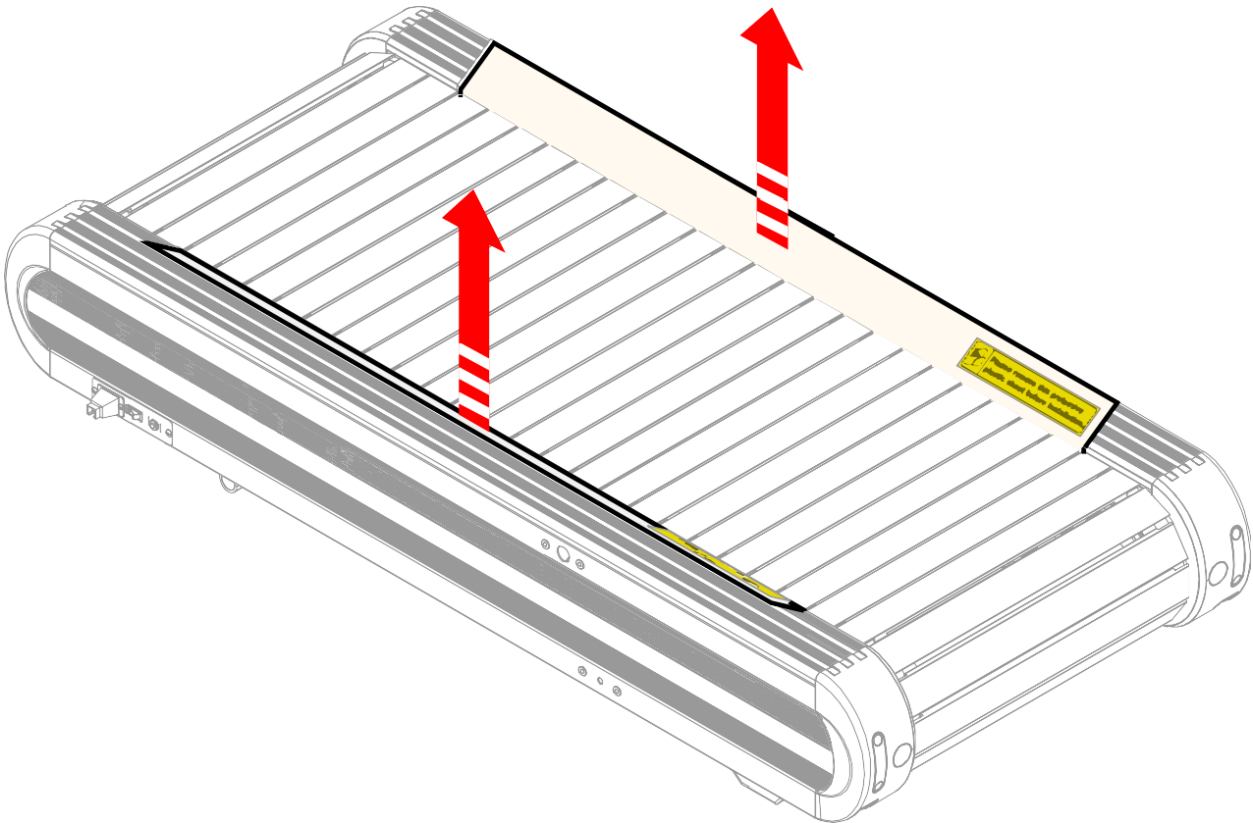



In case of danger, the machine assembly must be jointly carried out by two or more people and do not assemble alone.

STEP 1

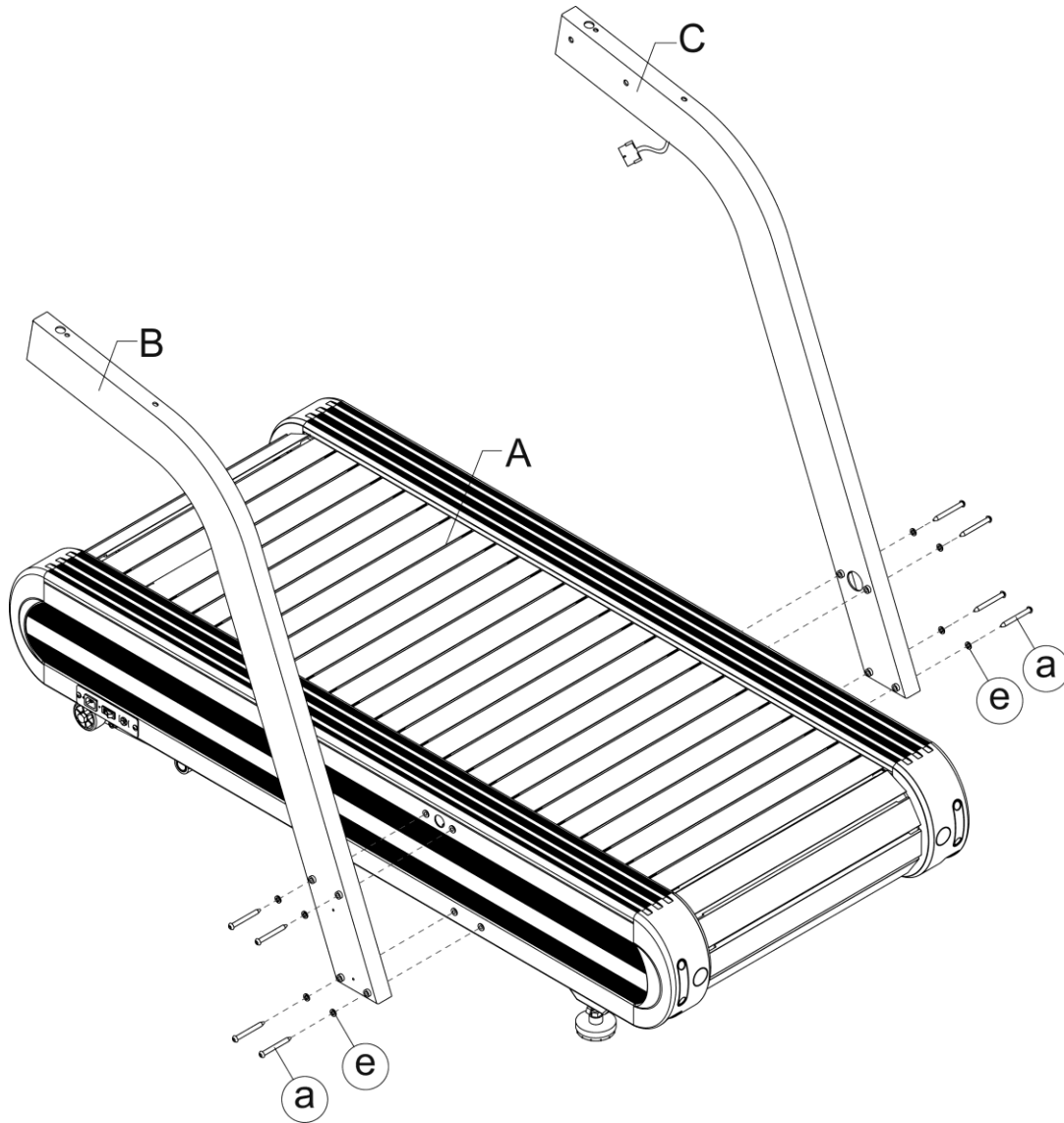

- 1 Use the magic tape attached to the left and right upright tube (B, C) to tie the wire on both sides of the frame, and then pull through the square hole under the left and right upright tube to the exit hole under the upright tube.
- 2 Fix the left and right treadmill's hand-stand pipes (B, C) by screw (a), spring washer (e) without fastening.

※ Please be careful not to clip the wire when assembling

STEP 2

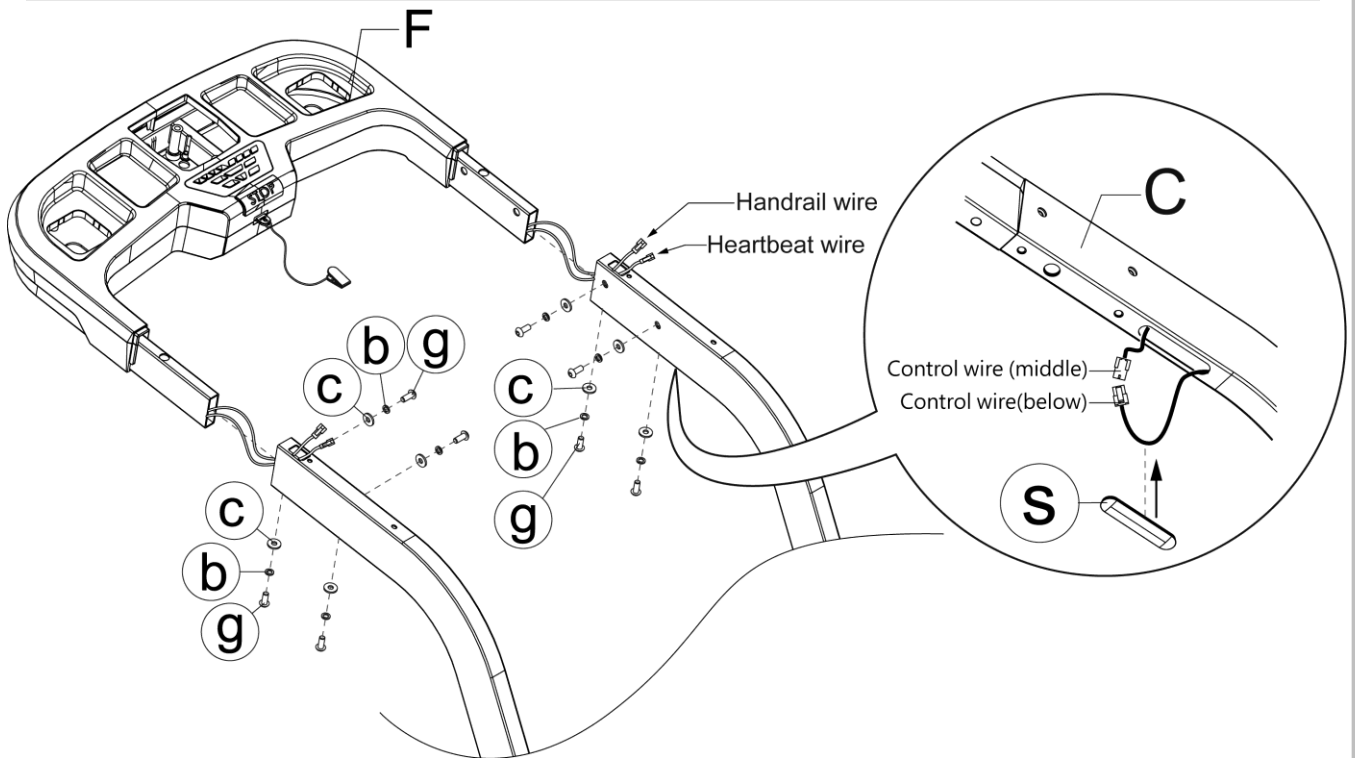

- 1 Connect the wire of the water cup holder to the wire of the left and right upright tube(B,C) as shown in the figure, then tidy up wires, insert the wire into the left and right upright tube(B,C). Finally, put the oval rubber cap (s) into the left and right upright tube (B, C).
- 2 Lock with screw (g) and washer (b, c) but not tightly. Confirm that the water cup frame (F) is locked with all the screws of the left and right treadmill's hand-stand pipes and then use the tool to lock all the screws.

※ **Please be careful not to clip the wire when assembling**

STEP 3

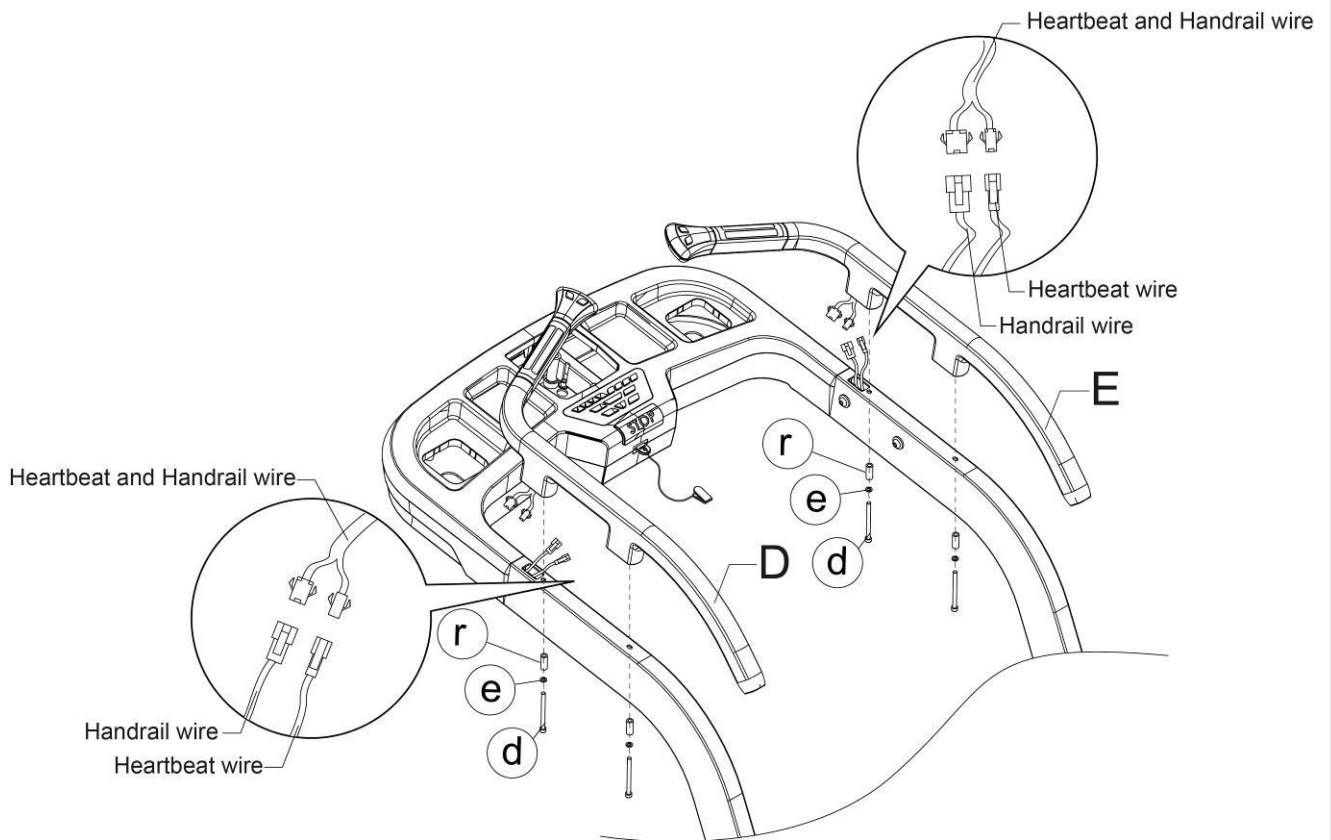

- 1 Connect the wires in the water bottle shelf with the left and right upright tubes (D、E) .
After arranging, insert into the upright tubes (D、E) .
- 2 Use screw (d), spring washer (e), Bushing (r) to lock the left and right handrail pipes (D, E) tightly as shown in the figure and fix them on the left and right treadmill's hand-stand pipes.

※ Please be careful not to clip the wire when assembling

STEP 4

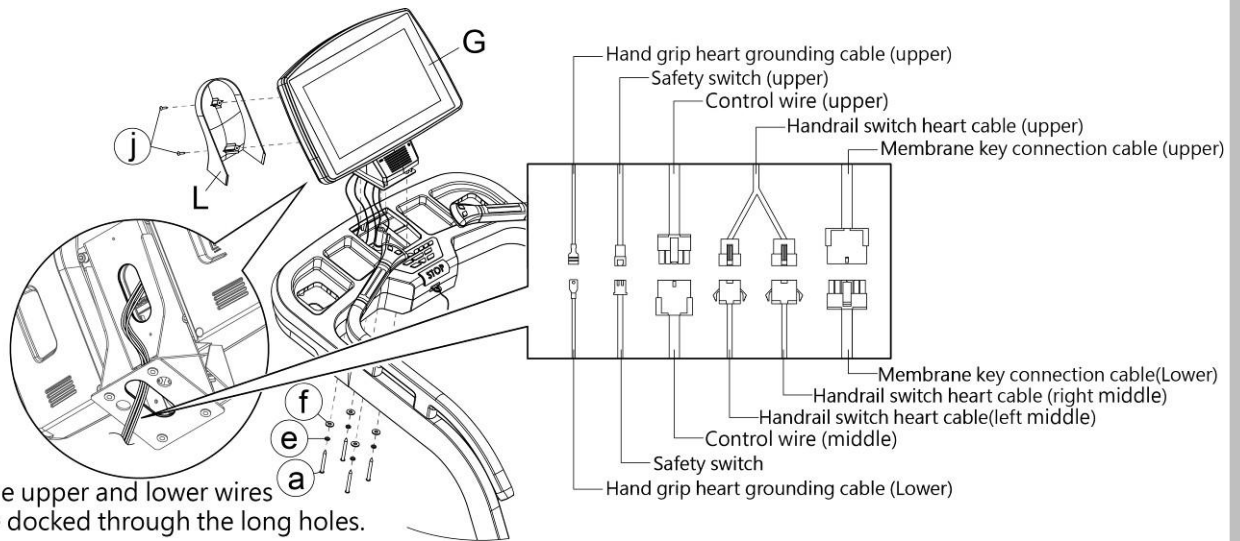

- 1 Cover the Electronic meter decorative cover (L) and lock it tightly with the screw (j), and pay attention that the cover should not be pressed on the wire.
- 2 Connect the wire of the water cup frame to the wire of the Electronic meter.
- 3 Put the Electronic meter (G) on the water cup frame previously assembled, Use the screw (a) and washer (e, f) to lock Electronic meter tightly and fix it on the water cup frame.

※ Please be careful not to clip the wire when assembling.

STEP 5

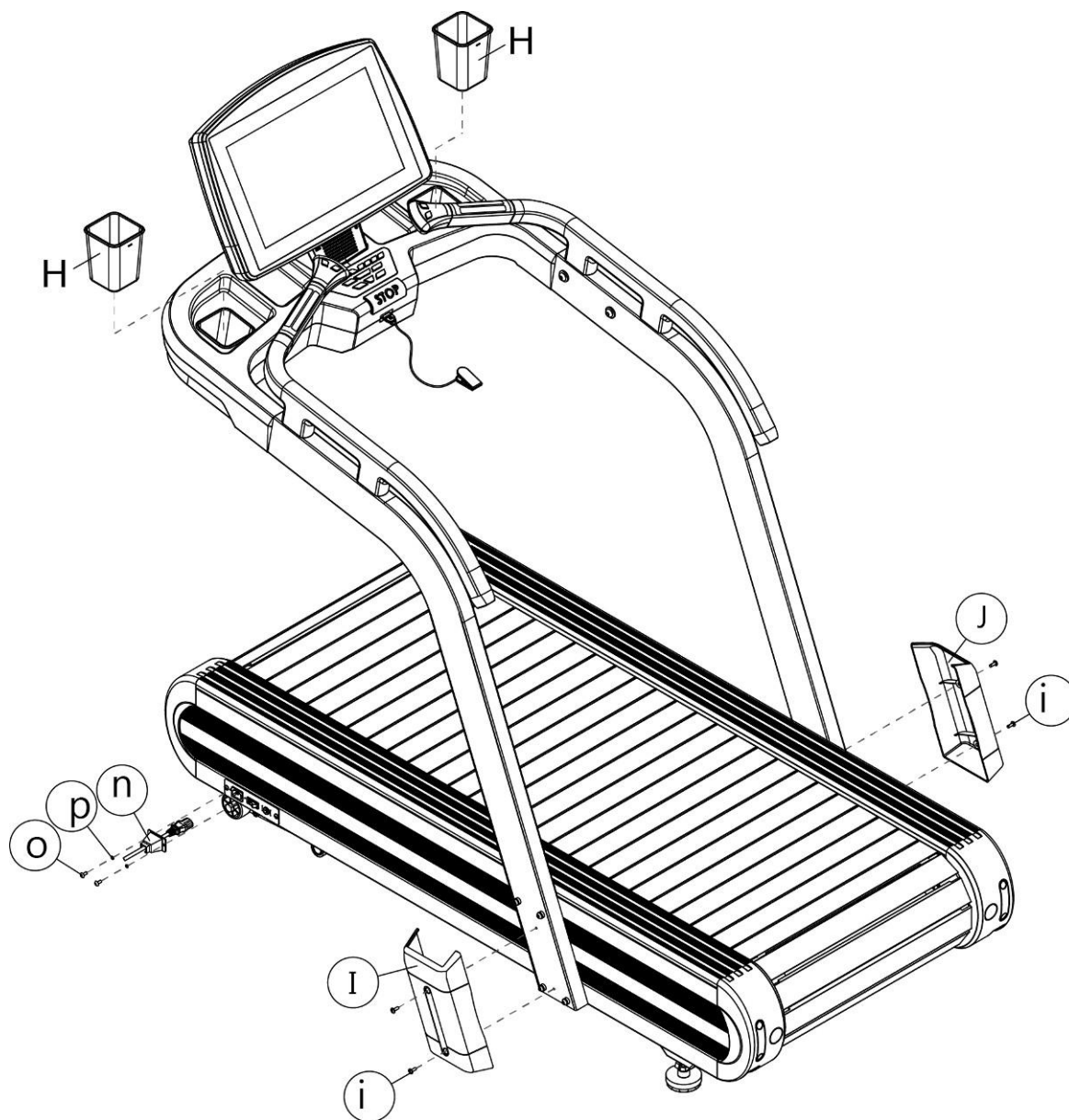

Cover the left and right stand pipe decorative covers (I, J), and tighten them with screws (i). Insert the power cord into the power cord socket according to the figure position. Cover the power cord switch sleeve (n) and lock it tightly with screws (o) and spring washer (p). Finally, put the water cup (H) into the rack frame.

CONSOLE OPERATION INSTRUCTION

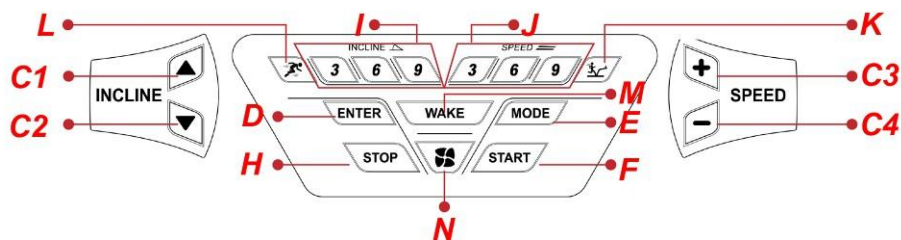
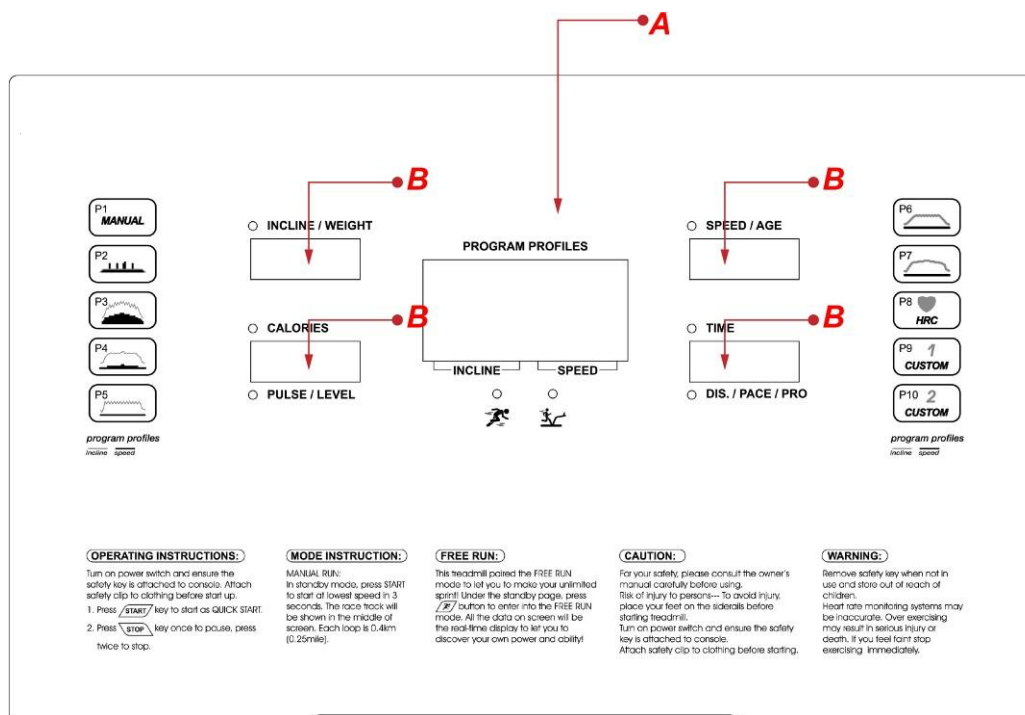

1.8. Computer console construction

A	WORKOUT PROFILE	Show the incline changes during the exercise, the height of the cursor means the percentage of the incline.
B	MESSAGE CENTER	Show the operation steps of all the programs and the relative information about all the control and conduction program operation, such as calorie, distance/stride, time, incline and speed.
C1	During exercise to increase incline angle	During exercise to increase incline angle, max is 15% (10% for free operating mode), STEP 1%.
C2	During exercise to decrease incline angle	During exercise to decrease incline angle, minimum is 0% , STEP 1%.

D	ENTER	Confirm the digital number for program setting or specific case selection, such as exercise time, speed, weight, distance, exercise target, gender, and target heart ratio and so on. Use SPEED"+", "-" to input information, press ENTRE to confirm.
E	MODE	Selection of PROGRAM theme, include P1~P10. Under free operating mode, only P1 is valid.
F	QUICK START	Press this key to get fast entrance to the user preset mode, no need to choose program setting, during program execution process, use SPEED"+", "-" key or INCLINE"+", "-" key to adjust incline and speed. After start, the initial speed is 0.5mph(0.8km)
H	During exercise, press this key to pause/stop	During exercise, press this key once to enter into pause status, press again to back to standby status.
I	Incline 3,6,9 fast key	During treadmill mode, press this key, incline will do 3,6,9 fast switch.
J	Speed 3,6,9 fast key	During treadmill mode, press this key, speed will do 3,6,9 fast switch. Under free operating mode, this key is invalid.
K	 Treadmill mode	Press this key, after start, enter into the treadmill functions. Under standby, the treadmill can switch between the pushing exercise mode and treadmill mode.
M	Wake	Energy-saving mode: if no usage for the treadmill lasting for 5 minutes, the machine will enter into energy saving mode, at that time, the screen of the computer console has no display. Press WAKE key to wake up the computer console.
N	Fan start/stop key	Control the fan start (full speed/half speed) and stop.

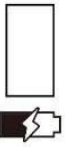
O	USB charge 	This hole is for iOS device or Android device charge, and the output current is 5V/1A
---	---	---

1. Start Display:

1. When the SAFETY KEY is taken off, all the windows will show ---- and the dot matrix window shows ↓. After put the SAFETY KEY back, Weight window blinks and displays preset value 70KG (150LBS), Step is 1. At this moment, the dot matrix window, whether you set or not set, press ENTER and the window will go back to the ready to start mode, the dot matrix window shows heart beating figure. The aim of setting a weight is to make a change of the CALORIES consuming. The setting can only be done after power-on. During PROGRAM, it will continue to use the preset value after power-on. If it is restarted, the weight needs to be set again.
2. During exercise, if the safety key falls down, the machine will stop operation, at that time, if insert back the safety key, the beeper will generate reminding sound and all the data will back to the initial status.
3. Under normal standby status, if you do not grab the heart sensor, the PULSE window will show HP video, but when you grab the heart sensor, you will see the heart data in the PULSE window.

2. Operation method:

1. Under standby status, press Mode key to enter into editing mode.
2. Under standby status, press Start key to enter into directly and start with Manu run.
3. for the sake of safety criterions, the incline function of this system only execute the automatic orientation action under the below conditions:
 - 3.1 During exercise, if press STOP KEY, the system will enter into PAUSE status and the

motor will stop while the incline motor will back to the initial point automatically.

3.2 When the setting program and the target is finished, or the execution time comes to the max, the system will enter into RUN END status, and the main motor will stop while the incline motor will back to the initial point automatically.

3.3 Under standby status, if the incline does not at the original point, press STOP for 5 seconds to execute the automatically and the incline will back to the initial point.

3.4 Under standby status, if the incline does not at the original point, press START key to start and the incline will back to the initial point automatically. During the automatic orientation action, if press STOP KEY, the action will stop.

3. Editing mode

1. Under standby mode, press Mode key and "+" , "-" key to choose Manu mode, Program mode.
2. Program mode: press "+" , "-" key to edit Program (P1~P10), PROGRAM LED blinks. Window will show P1~P10 for edition, press "+" , "-" key to edit. Press ENTER to dive into LEVEL option, window will show L1~L10, press "+" , "-" key to edit. Press ENTER to enter into TIME edition, the default data is 30 min, range is 20~99 min, STEP IS 1. After edition, press ENTER or START to start. During edition process, if press START key directly, the resting unedited will adopt the default data. During edition, the INCLINE and SPEED window will show the first level data, and the dot matrix window will show the relative image.
3. There are WARM UP and COOL DOWN functions. If change speed or incline during WARM UP or Program execution, then at the next level, the speed or incline will do progressive increase or decrease. COOL DOWN will not be affected, and only accept STOP during execution.
4. There are 30 levels in PROGRAM, the first 3 levels is WARM UP, and the last 3 levels is COOL DOWN, each last 3 minutes. The setting time, except for the 6 minutes mentioned before, the rest time will be executed by the 21 levels of PROGRAM averagely.
5. 9 HOLES mode has no WARM UP and COOL DOWN functions, when the distance comes to 3.5KM, the motor will stop, incline back to 0 and show " END".

4. Program operation and instruction:

Manu mode

1. After pressing Start key, 3 seconds countdown starts, after that, the motor will start with speed 0.8KPH (0.5MPH) , and the dot matrix window will run in anti-lock direction with playground way, each circle is 0.4KM(0.25MIL).
2. Speed STEP is 0.1, press speed increase/decrease to choose (speed increase/decrease range is 0.1), or press speed fast key **3、6、9 to choose.**
3. Incline STEP is 0.1, press speed increase/decrease to choose (speed increase/decrease range is 1), or press speed fast key **3、6、9 to choose.**
4. After pressing Mode key, the TIME/DISTANCE can do switch.
5. When detect the heartbeat, the heart window will show heartbeat data.
6. During exercise, after pressing Stop key, the motor will stop, the incline motor will back to initial point and the time window will show "Stop"; if press Start key, 3 seconds

countdown starts, after that, the motor will start again, the speed will maintain the speed before stop, and incline will up to the setting height before stop.

7. During Stop, press Stop key for 3 seconds, back to standby page.
8. After End status, press Stop key for long time, back to standby page.
9. Preset time is 20, the range is 5~99.
10. Press FAN key, to start fan high speed/low speed/turn off fan.
11. USB charge instruction

This hole is for iOS device or Android device charge, and the output current is 1A

5. Program mode(treadmill mode)

P1 is same as **Manu** mode.

P2 9 hole LEVEL: default 1, range 1~10, step1, distance counting 3500 meters.

P3 hill climb LEVEL: default 1, range 1~10, step 1。
time: preset 30min; range 20~99min, step 1 min。











P4 hill run LEVEL: default 1, range 1~10, step 1。
time: preset 30min, range 20~99min, step 1 min。

P5 interval LEVEL: default 1, range 1~10, step 1。
time: preset 30min, range 20~99min, step 1 min。

P6 rolling LEVEL: default 1, range 1~10, step1。
time: preset 30min, range 20~99min, step 1 min。

P7 Weight loss LEVEL: default 1, range 1~10, step 1。
time: preset 30min, range 20~99min, step 1 min。

P8 HRC HRC function: (this function should match with heartbeat breast binding belt)

1. This program is aimed at training, during usage, when heart beat comes to the preset data, the angle, speed will keep stable to maintain the heartbeat within the range to get the training effect.
2. When the LED signal light of **AGE** blinks, press   or   to adjust age, after setting, press  to enter into next option. Age preset :30, setting range: 13~80, Step is 1.
3. At that time, the LED signal light of **PULSE** will blink, and the program will demand the heartbeat input, and the data will change according to the ages, the data you can take the appendix chart for reference, and choose the suitable data from the chart. You can adjust heartbeat by pressing   or  . If you do no change anything, press , the program, will start execution with the preset data and enter into the next option.
4. At that time, the **TIME** window will blink, and the program will demand the time input,

you can press ▲ ▼ or + - to set the exercise time you want, or press  directly to adopt countdown way to exercise.

*time range: 5~99 min, preset 20min, step is 1.)

** This chart is about Age and Pulse Value (Default Value) for HRC Function:

Age	BPM			Age	BPM			Age	BPM			Age	BPM		
	H	Default Value	L		H	Default Value	L		H	Default Value	L		H	Default Value	L
13	197	124	124	31	180	113	113	49	162	103	103	67	145	92	92
14	196	124	124	32	179	113	113	50	162	102	102	68	144	91	91
15	195	123	123	33	178	112	112	51	161	101	101	69	143	91	91
16	194	122	122	34	177	112	112	52	160	101	101	70	143	90	90
17	193	122	122	35	176	111	111	53	159	100	100	71	142	90	89
18	192	121	121	36	175	110	110	54	158	100	100	72	141	90	89
19	191	121	121	37	174	110	110	55	157	99	99	73	140	90	88
20	190	120	120	38	173	109	109	56	156	98	98	74	139	90	88
21	189	119	119	39	172	109	109	57	155	98	98	75	138	90	87
22	188	119	119	40	171	108	108	58	154	97	97	76	137	90	86
23	187	118	118	41	170	107	107	59	153	97	97	77	136	90	86
24	186	118	118	42	169	107	107	60	152	96	96	78	135	90	85
25	185	117	117	43	168	106	106	61	151	95	95	79	134	90	85
26	184	116	116	44	167	106	106	62	150	95	95	80	133	90	84
27	183	116	116	45	166	105	105	63	149	94	94				
28	182	115	115	46	165	104	104	64	148	94	94				
29	181	115	115	47	164	104	104	65	147	93	93				
30	181	114	114	48	163	103	103	66	146	92	92				

P9. P10 are both CUSTOM

time: preset 30min, range 20~99min, step1 min.

- (1) There are 30 levels (SE01~SE30) to set in the PROGRAM, and the default are all adopt the minimum data.
- (2) Setting: time、 program execute data. The setting time will be executed averagely in the 30 levels.
- (3) Under standby mode to enter into CUSTOM mode, after setting time, press enter to enter into the setting of speed and incline you want, there are 30 levels you can set, after setting, press start directly to start.

SPEED AND ELEVATION CHANGES

SPEED AND ELEVATION CHANGES

HILL CLIMB		1	2	3	4	5	6	7	8	9	10	11	12	13	14	15	16	17	18	19	20	21	22	23	24	25	26	27	28	29	30		
Level 1	ELEVATION	0.0	0.0	0.0	1.0	1.0	1.0	1.0	2.0	2.0	2.0	2.0	3.0	3.0	3.0	3.0	3.0	3.0	3.0	2.0	2.0	2.0	2.0	1.0	1.0	1.0	1.0	1.0	0.0	0.0			
	(MPH)	1.5	2.0	2.5	3.5	2.0	3.0	2.0	4.0	2.0	4.0	2.0	4.0	2.5	4.0	2.5	4.0	2.5	4.0	2.5	4.0	2.5	4.0	2.0	4.0	2.0	3.5	3.0	2.5	2.0	1.5		
	(KPH)	2.4	3.2	4.0	5.6	3.2	4.8	3.2	6.4	3.2	6.4	3.2	6.4	4.0	6.4	4.0	6.4	4.0	6.4	4.0	6.4	4.0	6.4	3.2	6.4	3.2	5.6	4.8	4.0	3.2	2.4		
Level 2	ELEVATION	0.0	0.0	1.0	1.0	1.0	2.0	2.0	2.0	2.0	3.0	3.0	3.0	3.0	4.0	3.0	4.0	3.0	3.0	3.0	3.0	2.0	2.0	2.0	2.0	1.0	1.0	1.0	1.0	0.0	0.0		
	(MPH)	1.5	2.0	2.5	4.0	2.5	3.5	2.5	4.5	2.5	4.5	2.5	4.5	3.0	4.5	3.0	4.5	3.5	4.5	3.0	4.5	2.5	4.5	2.5	4.5	2.5	4.0	3.5	2.5	2.0	1.5		
	(KPH)	2.4	3.2	4.0	6.4	4.0	5.6	4.0	7.2	4.0	7.2	4.0	7.2	4.8	7.2	4.8	7.2	5.6	7.2	4.8	7.2	4.0	7.2	4.0	7.2	4.0	6.4	5.6	4.0	3.2	2.4		
Level 3	ELEVATION	0.0	1.0	1.0	2.0	2.0	2.0	2.0	3.0	3.0	3.0	3.0	4.0	4.0	4.0	4.0	4.0	4.0	4.0	3.0	3.0	3.0	3.0	2.0	2.0	2.0	2.0	1.0	1.0	1.0	0.0		
	(MPH)	1.5	2.0	2.5	4.5	2.5	4.0	3.0	5.0	3.0	5.0	3.0	5.0	3.5	5.0	3.5	5.0	3.5	5.0	3.5	5.0	3.0	5.0	3.0	5.0	3.0	4.5	3.5	2.5	2.0	1.5		
	(KPH)	2.4	3.2	4.0	7.2	4.0	6.4	4.8	8.0	4.8	8.0	4.8	8.0	5.6	8.0	5.6	8.0	5.6	8.0	5.6	8.0	5.6	8.0	4.8	8.0	4.8	7.2	5.6	4.0	3.2	2.4		
Level 4	ELEVATION	1.0	1.0	2.0	2.0	2.0	3.0	3.0	3.0	3.0	4.0	4.0	4.0	4.0	5.0	5.0	5.0	5.0	4.0	4.0	4.0	4.0	3.0	3.0	3.0	3.0	2.0	2.0	2.0	1.0	1.0		
	(MPH)	2.0	2.5	3.0	5.0	3.0	5.0	3.0	5.5	3.5	5.5	3.5	5.5	4.0	5.5	4.0	5.5	4.0	5.5	4.0	5.5	3.5	5.5	3.5	5.5	3.5	5.0	4.0	3.0	2.5	2.0		
	(KPH)	3.2	4.0	4.8	8.0	4.8	8.0	4.8	8.8	5.6	8.8	5.6	8.8	6.4	8.8	6.4	8.8	6.4	8.8	6.4	8.8	6.4	8.8	5.6	8.8	5.6	8.0	6.4	4.8	4.0	3.2		
Level 5	ELEVATION	1.0	2.0	2.0	3.0	3.0	3.0	3.0	4.0	4.0	4.0	4.0	5.0	5.0	5.0	5.0	5.0	5.0	5.0	4.0	4.0	4.0	4.0	3.0	3.0	3.0	3.0	2.0	2.0	2.0	1.0		
	(MPH)	2.0	2.5	3.0	5.5	3.5	5.5	3.5	6.0	4.0	6.0	4.0	6.0	4.5	6.0	4.5	6.0	4.5	6.0	4.5	6.0	4.0	6.0	4.0	6.0	4.0	6.0	3.5	5.5	4.5	3.0	2.5	2.0
	(KPH)	3.2	4.0	4.8	8.8	5.6	8.8	5.6	9.6	6.4	9.6	6.4	9.6	7.2	9.6	7.2	9.6	7.2	9.6	7.2	9.6	7.2	9.6	6.4	9.6	6.4	9.6	5.6	8.8	7.2	4.8	4.0	3.2
Level 6	ELEVATION	2.0	2.0	3.0	3.0	3.0	4.0	4.0	4.0	4.0	5.0	5.0	5.0	5.0	6.0	6.0	6.0	6.0	5.0	5.0	5.0	5.0	4.0	4.0	4.0	4.0	3.0	3.0	3.0	2.0	2.0		
	(MPH)	2.0	2.5	3.0	6.0	4.0	6.0	4.0	6.5	4.5	6.5	4.5	6.5	5.0	6.5	5.0	6.5	5.0	6.5	5.0	6.5	4.5	6.5	4.5	6.5	4.0	6.0	5.0	3.0	2.5	2.0		
	(KPH)	3.2	4.0	4.8	9.6	6.4	9.6	6.4	10.4	7.2	10.4	7.2	10.4	8.0	10.4	8.0	10.4	8.0	10.4	8.0	10.4	8.0	10.4	7.2	10.4	7.2	10.4	6.4	9.6	8.0	4.8	4.0	3.2
Level 7	ELEVATION	2.0	2.0	3.0	4.0	4.0	4.0	4.0	5.0	5.0	5.0	5.0	6.0	6.0	6.0	6.0	6.0	6.0	6.0	6.0	5.0	5.0	5.0	5.0	4.0	4.0	4.0	4.0	3.0	3.0	2.0		
	(MPH)	2.0	2.5	3.0	6.5	4.5	6.5	5.0	7.0	5.0	7.0	5.0	7.0	5.5	7.0	5.5	7.0	5.5	7.0	5.5	7.0	5.5	7.0	5.0	7.0	5.0	7.0	4.5	7.0	5.0	3.5	3.0	2.5
	(KPH)	3.2	4.0	4.8	10.4	7.2	10.4	8.0	11.2	8.0	11.2	8.0	11.2	8.8	11.2	8.8	11.2	8.8	11.2	8.8	11.2	8.8	11.2	8.0	11.2	8.0	11.2	7.2	11.2	8.0	5.6	4.8	4.0
Level 8	ELEVATION	2.0	3.0	3.0	4.0	4.0	5.0	5.0	5.0	5.0	6.0	6.0	6.0	6.0	7.0	7.0	7.0	7.0	6.0	6.0	6.0	6.0	5.0	5.0	5.0	5.0	4.0	4.0	4.0	3.0	2.0		
	(MPH)	2.5	3.0	3.5	6.5	5.0	7.0	5.0	7.5	5.5	7.5	5.5	7.5	6.0	7.5	6.0	7.5	6.0	7.5	6.0	7.5	6.0	7.5	5.5	7.5	5.5	7.0	5.0	7.0	5.0	3.5	3.0	2.5
	(KPH)	4.0	4.8	5.6	10.4	8.0	11.2	8.0	12.0	8.8	12.0	8.8	12.0	9.6	12.0	9.6	12.0	9.6	12.0	9.6	12.0	9.6	12.0	8.8	12.0	8.8	11.2	8.0	11.2	8.0	5.6	4.8	4.0
Level 9	ELEVATION	2.0	3.0	4.0	5.0	5.0	5.0	5.0	6.0	6.0	6.0	6.0	7.0	7.0	7.0	7.0	7.0	7.0	7.0	7.0	6.0	6.0	6.0	6.0	5.0	5.0	5.0	5.0	4.0	4.0	3.0	2.0	
	(MPH)	2.5	3.0	3.5	6.5	5.5	7.5	5.5	8.0	6.0	8.0	6.0	8.0	6.5	8.0	6.5	8.0	6.5	8.0	6.5	8.0	6.5	8.0	6.0	8.0	6.0	7.5	5.5	7.5	5.0	3.5	3.0	2.5
	(KPH)	4.0	4.8	5.6	10.4	8.8	12.0	8.8	12.8	9.6	12.8	9.6	12.8	10.4	12.8	10.4	12.8	10.4	12.8	10.4	12.8	10.4	12.8	9.6	12.8	9.6	12.0	8.8	12.0	8.0	5.6	4.8	4.0
Level 10	ELEVATION	2.0	3.0	5.0	5.0	5.0	6.0	6.0	6.0	6.0	7.0	7.0	7.0	7.0	8.0	8.0	8.0	8.0	7.0	7.0	7.0	7.0	6.0	6.0	6.0	6.0	5.0	5.0	4.0	4.0	3.0	2.0	
	(MPH)	2.5	3.0	3.5	6.5	6.0	8.0	6.0	8.0	6.5	8.5	6.5	8.5	7.0	8.5	7.0	8.5	7.0	8.5	7.0	8.5	7.0	8.5	6.5	8.5	6.5	8.5	6.0	7.5	6.5	3.5	3.0	2.5
	(KPH)	4.0	4.8	5.6	10.4	9.6	12.8	9.6	12.8	10.4	13.6	10.4	13.6	11.2	13.6	11.2	13.6	11.2	13.6	11.2	13.6	11.2	13.6	10.4	13.6	10.4	13.6	9.6	12.0	10.4	5.6	4.8	4.0

SPEED AND ELEVATION CHANGES

SPEED AND ELEVATION CHANGES

HILL RUN		1	2	3	4	5	6	7	8	9	10	11	12	13	14	15	16	17	18	19	20	21	22	23	24	25	26	27	28	29	30
Level 1	ELEVATION	0.0	0.0	0.0	0.0	0.0	0.0	0.0	0.0	0.0	0.0	0.0	0.0	0.0	0.0	0.0	0.0	0.0	0.0	0.0	0.0	0.0	0.0	0.0	0.0	0.0	0.0	0.0	0.0	0.0	
	(MPH)	1.5	2.0	2.5	3.0	3.5	4.0	3.5	4.0	3.5	4.0	3.5	4.0	3.5	4.0	3.5	4.0	3.5	4.0	3.5	4.0	3.5	4.0	3.5	4.0	3.5	4.0	3.0	2.5	2.0	1.5
Level 2	(KPH)	2.4	3.2	4.0	4.8	5.6	6.4	5.6	6.4	5.6	6.4	5.6	6.4	5.6	6.4	5.6	6.4	5.6	6.4	5.6	6.4	5.6	6.4	5.6	6.4	5.6	6.4	4.8	4.0	3.2	2.4
	ELEVATION	0.0	0.0	0.0	0.0	0.0	0.0	0.0	0.0	0.0	0.0	0.0	0.0	0.0	0.0	0.0	0.0	0.0	0.0	0.0	0.0	0.0	0.0	0.0	0.0	0.0	0.0	0.0	0.0	0.0	0.0
Level 3	(MPH)	1.5	2.0	2.5	3.5	4.0	4.5	4.0	4.5	4.0	4.5	4.0	4.5	4.0	4.5	4.0	4.5	4.0	4.5	4.0	4.5	4.0	4.5	4.0	4.5	4.0	3.5	3.0	2.5	2.0	1.5
	(KPH)	2.4	3.2	4.0	5.6	6.4	7.2	6.4	7.2	6.4	7.2	6.4	7.2	6.4	7.2	6.4	7.2	6.4	7.2	6.4	7.2	6.4	7.2	6.4	7.2	6.4	5.6	4.8	4.0	3.2	2.4
Level 4	ELEVATION	0.0	0.0	0.0	0.0	1.0	1.0	1.0	1.0	1.0	1.0	1.0	0.0	0.0	0.0	1.0	1.0	1.0	0.0	0.0	0.0	0.0	1.0	1.0	1.0	1.0	1.0	0.0	0.0	0.0	0.0
	(MPH)	2.0	2.5	3.0	4.5	5.0	5.5	5.0	5.5	5.0	5.5	5.0	5.5	5.0	5.5	5.0	5.5	5.0	5.5	5.0	5.5	5.0	5.5	5.0	5.5	5.0	4.5	4.0	3.0	2.5	2.0
Level 5	(KPH)	3.2	4.0	4.8	7.2	8.0	8.8	8.0	8.8	8.0	8.8	8.0	8.8	8.0	8.8	8.0	8.8	8.0	8.8	8.0	8.8	8.0	8.8	8.0	8.8	8.0	7.2	6.4	4.8	4.0	3.2
	ELEVATION	0.0	0.0	0.0	0.0	0.0	1.0	1.0	1.0	1.0	1.0	1.0	1.0	1.0	1.0	1.0	1.0	1.0	1.0	1.0	1.0	1.0	1.0	1.0	1.0	1.0	1.0	5.0	4.0	3.0	2.0
Level 6	(MPH)	2.0	2.5	3.0	5.0	5.5	6.0	5.5	6.0	5.5	6.0	5.5	6.0	5.5	6.0	5.5	6.0	5.5	6.0	5.5	6.0	5.5	6.0	5.5	6.0	5.5	5.0	4.5	3.0	2.5	2.0
	(KPH)	3.2	4.0	4.8	8.0	8.8	9.6	8.8	9.6	8.8	9.6	8.8	9.6	8.8	9.6	8.8	9.6	8.8	9.6	8.8	9.6	8.8	9.6	8.8	9.6	8.8	8.0	7.2	4.8	4.0	3.2
Level 7	ELEVATION	0.0	0.0	0.0	0.0	0.0	1.0	1.0	1.0	1.0	1.0	1.0	1.0	1.0	1.0	1.0	1.0	1.0	1.0	1.0	1.0	1.0	1.0	1.0	1.0	1.0	1.0	0.0	0.0	0.0	0.0
	(MPH)	2.0	2.5	3.0	6.0	6.5	7.0	6.5	7.0	6.5	7.0	6.5	7.0	6.5	7.0	6.5	7.0	6.5	7.0	6.5	7.0	6.5	7.0	6.5	7.0	6.5	6.0	5.5	3.0	2.5	2.0
Level 8	(KPH)	3.2	4.0	4.8	9.6	10.4	11.2	10.4	11.2	10.4	11.2	10.4	11.2	10.4	11.2	10.4	11.2	10.4	11.2	10.4	11.2	10.4	11.2	10.4	11.2	10.4	9.6	8.8	4.8	4.0	3.2
	ELEVATION	1.0	1.0	1.0	1.0	1.0	1.0	1.0	1.0	1.0	1.0	1.0	2.0	2.0	2.0	1.0	1.0	1.0	2.0	2.0	2.0	1.0	1.0	1.0	1.0	1.0	1.0	1.0	1.0	1.0	1.0
Level 9	(MPH)	2.5	3.0	3.5	6.5	7.0	7.5	7.0	7.5	7.0	7.5	7.0	7.5	7.0	7.5	7.0	7.5	7.0	7.5	7.0	7.5	7.0	7.5	7.0	7.5	7.0	6.5	6.0	3.5	3.0	2.5
	(KPH)	4.0	4.8	5.6	10.4	11.2	12.0	11.2	12.0	11.2	12.0	11.2	12.0	11.2	12.0	11.2	12.0	11.2	12.0	11.2	12.0	11.2	12.0	11.2	12.0	11.2	10.4	9.6	5.6	4.8	4.0
Level 10	ELEVATION	1.0	1.0	1.0	1.0	1.0	1.0	1.0	1.0	1.0	2.0	2.0	2.0	2.0	2.0	2.0	2.0	2.0	2.0	2.0	2.0	2.0	2.0	2.0	2.0	2.0	1.0	1.0	1.0	1.0	1.0
	(MPH)	2.5	3.0	3.5	6.5	7.5	8.0	7.5	8.0	7.5	8.0	7.5	8.0	7.5	8.0	7.5	8.0	7.5	8.0	7.5	8.0	7.5	8.0	7.5	8.0	7.5	7.0	6.5	3.5	3.0	2.5
	(KPH)	4.0	4.8	5.6	10.4	12.0	13.6	12.8	13.6	12.8	13.6	12.8	13.6	12.8	13.6	12.8	13.6	12.8	13.6	12.8	13.6	12.8	13.6	12.8	13.6	12.8	12.0	10.4	5.6	4.8	4.0

